

Table of contents

	Page
Safety notes / Technical support	2

Introduction	3

Technical data	4
Electrical data	4
Mechanical data	7
Transport and Storage	7

Operating conditions	9

Approvals	11

Dimensions	11

Accessories	18

Installation	19
Mechanical installation	19
Electrical installation	25

Operation	34
General	34
Operation with IO-Link	35

Troubleshooting	42

Maintenance	43

Disposal	44

Subject to technical change.

We assume no liability for content errors.

Different variations than specified are possible.
 Please contact our technical consultants.

Safety notes / Technical support

Special attention must be paid to warnings and notes as follows:

- Installation, maintenance and commissioning may be accomplished only by qualified technical personnel.
- The product must be used only in the manner outlined in this instruction manual.



WARNING

Relates to a caution symbol on the product: A failure to observe the necessary precautions can result in death, serious injury and/or considerable material damage.



WARNING

Relates to a caution symbol on the product: Risk of electric shock.



WARNING

A failure to observe the necessary precautions can result in death, serious injury and/or considerable material damage. This symbol is used, when there is no corresponding caution symbol on the product.

CAUTION A failure to observe the necessary precautions can result in considerable material damage.

Safety symbols (in manual and on product)



CAUTION: refer to accompanying documents (manual) for details.



Earth (ground) Terminal



Protective Conductor Terminal

Technical support

Please contact your local supplier (for address see www.uwtgroup.com). Otherwise you can contact:

UWT GmbH
Westendstr. 5
D-87488 Betzigau
Germany

Tel.: 0049 (0)831 57123-0
Fax: 0049 (0)831 76879
info@uwtgroup.com
www.uwtgroup.com

Introduction

Applications

The Vibranivo series VN 7000 is a level limit switch for detection of liquids. It works in all types of vessels, pipes or agitator tanks within a wide range of applications like:

- Food, brewery, dairy, beverage and pharmaceuticals
- Chemical and petrochemical
- Water and waste water
- Machine building industry

It can also be used for leakage detection in double walled vessels, tanks or collecting ponds

Features

Process

- Level limit detection in liquids
- Wide range of applications
- Full-, demand-, empty detector
- Overflow and Leakage detection
- Independent from dielectricity and conductivity
- Insensitive to material buildup, flow, turbulences and air bubbles
- Allows measurement of most applications without sensitivity setting
- CIP and SIP capable
- No maintenance

Approvals

- CE, UKCA, usFMc, WHG, EHEDG

Electronics

- IO-Link, PNP, NPN or Push-Pull output (configurable)
- 3-wire PNP
- 2-wire without contact
- M12 plug, Valve plug
- Bright signal LED, selectable colours
- Sensitivity and signal delay setting by IO-Link

Mechanics

- Compact unit
- Short vibration fork length
- Pipe extension
- Optional sliding sleeve allows to change the switch point easily during operation
- Various process connections
- Resistant to temperature, vibration, humidity, condensation
- Corrosion resistant construction (316L stainless steel)
- Hygienic design

Measurement principle

The piezo-electrically stimulated vibration fork vibrates at its mechanical resonance frequency. If the vibration fork is covered by liquid, the change of resonance frequency thus generated is detected electronically and a corresponding signal output is actuated.

Electrical data

IO-Link

Power supply	10,8 - 30 V DC incl. 10% of EN 61010-1 Operation with IO-Link requires min. 18 V Current consumption: <55 mA
Signal outputs Electrical ratings	SSC1 and SSC2: Max. current: One output active: 200 mA Both outputs active: 100 mA each (short-circuit proof) Voltage drop: <2 V
SSC1 Configuration	SIO mode*: Factory sett PNP (FSL) Other than factory setting can be configured via IO-Link as follows: PNP (FSH) or NPN (FSH or FSL) or Push/pull (FSH or FSL) COM-mode IO-Link communication *Note: If there is no IO-Link communication, the device operates in the SIO mode
SSC2 Configuration	Factory setting PNP (FSH) Note: SSC2 PNP is opposite to SSC1 PNP (antivalent) Other than factory setting can be configured via IO-Link as follows: PNP (FSL) or NPN (FSH or FSL) or Push/pull (FSH or FSL)
Safety operation (FSL,FSH)	Configurable via IO-Link
Signal delay	Factory setting Vibration fork uncovered -> covered ca. 0,5 sec Vibration fork covered -> uncovered ca. 1,0 sec Other than factory setting can be configured via IO-Link
Signal light	Factory setting Power (green), Signal output (yellow), Diagnostics (red) Other than factory setting can be configured via IO-Link: Blue, Purple and White LED is present on transparent lid. For devices with stainless steel lid, no transparent lid is present, LED's on M12 connector are used instead.
Diagnostics	Test magnet Manually change the actual output state (covered / uncovered) Self diagnostics Permanent monitoring of the unit function
Sensitivity (Density)	Factory setting >0,7 g/cm ³ Optional or by configuration via IO-Link >0,5 g/cm ³
Electrical connection	M12x1 according to IEC 61076-2-101, male, 4-pole, coding A-standard
Overvoltage category	II
Installation category (Protection class)	III

Electrical data

3-wire PNP

Power supply	10,8 - 30 V DC incl. 10% of EN 61010-1 Current consumption: <55 mA
Signal outputs Electrical ratings	Max. current: 200 mA Both outputs active (possibility with M12 plug): 100 mA each (short-circuit proof) Voltage drop: <2 V
Safety operation (FSL,FSH)	Configurable by wiring the power supply and the load on respective terminals. See wiring diagram.
Signal delay	Vibration fork uncovered -> covered ca. 0,5 sec Vibration fork covered -> uncovered ca. 1,0 sec
Signal light	Power (green), Signal output (yellow), Diagnostics (red) LED is present on transparent lid. For devices with stainless steel lid, no transparent lid is present, LED's on M12 connector are used instead.
Diagnostics	Test magnet: Manually change the actual output state (covered / uncovered) Self diagnostics: Permanent monitoring of the unit function
Sensitivity (Density)	>0,7 g/cm ³
Electrical connection	M12 plug: M12x1 accord. to IEC 61076-2-101, male, 4-pole, coding A-standard Valve plug: ISO 4400. Fitting to cable diameter 4,5 .. 7 mm (0.18 ..0.28")
Overvoltage category	II
Installation category (Protection class)	III

Electrical data

2-wire without contact

Power supply	20 - 253V 50/60 Hz	incl. 10% of EN 61010-1
	20 - 253V DC	incl. 10% of EN 61010-1
	Power consumption:	max. 0,5W

Signal outputs Electrical ratings	Closed circuit:	Voltage drop on terminals: max. 3 V Load current: min. 10mA max. 250 mA permanent, 2 A <200 ms
	Open circuit:	Cutoff current: max. 3,8mA

Rated coil power when connecting a relay (load):

Supply voltage	min.*	max.
24V DC	0,75W	5W
110V AC	1,5 VA	28 VA
230V AC	2,5 VA	58 VA

* The stated minimum values consider a release voltage, which is required by a relay to open safely. When using relays with lower coil power, a parallel R (for DC) or parallel RC (for AC) can raise the total load above the stated minimum values.

Safety operation (FSL,FSH)	Configurable by wiring on respective terminals. See wiring diagram.
---------------------------------------	--

Signal delay	Vibration fork uncovered -> covered	ca. 0,5 sec
	Vibration fork covered -> uncovered	ca. 1,0 sec

Signal light	Power (green), Signal output (yellow), Diagnostics (red)
	LED is present on transparent lid.

Diagnostics	Test magnet: Manually change the actual output state (covered / uncovered) Self diagnostics: Permanent monitoring of the unit function
--------------------	---

Sensitivity (Density)	>0,7 g/cm ³
------------------------------	------------------------

Electrical connection	Valve plug: ISO 4400. Fitting to cable diameter 4,5 .. 7mm (0.18 ..0.28")
------------------------------	---

Overvoltage category	II
-----------------------------	----

Installation category (Protection class)	I
---	---

Mechanical data

Process connection	Thread:	G 1/2", G 3/4", G 1"; DIN ISO 228-1 NPT 1/2", NPT 3/4", NPT 1"; ASME B 1.20.1
	Thread for hygiene adapter:	G 3/4", G 1"; DIN ISO 228-1 M24 x 1,5 DIN 13
	Tri-clamp (accessory):	DN25 (1"), DN40 (1 1/2"), DN50 (2") DIN 32676 Type A (DIN 11851) and DIN 32676 Type C (ASME BPE 2009)
	Flange (screwed):	DN25 PN16/40, DN40 PN16/40, DN50 PN16/25/40 EN 1092-1 type A flat faced ASME 1", 1 1/2", 2"; 150lbs, 300lbs B16.5, raised face
Wetted sensor material	Process connection:	1.4404 (316L)
	Pipe extension (VN 7130):	1.4404 (316L)
	Vibration fork:	1.4404 (316L)
	Flat sealing	G-threads, non hygienic: AFM30
Wetted sensor surface	Non hygienic:	Ra < 3.2 µm (126 µin)
	Hygienic:	Ra < 0.76 µm (30 µin) Ra not defined at the welding seam
Extension length "L"	VN 7120:	64 mm (2.52") 75 mm (2.95"), G1" hygienic 104 mm (4.09"), elongated switchpoint 115 mm (4.53"), elongated switchpoint G1" hygienic
	VN 7130:	115 (4.53") ... 4.000 mm (157") 115 (4.53") ... 1.500 mm (59"), 1/2" process connection 115 (4.53") ... 1.000 mm (39.4"), hygienic
Tolerance length "L"	VN 7120:	±2 mm (±0.08")
	VN 7130 Pipe extension:	±5 mm (±0.2")
Material not in contact with process	Housing:	1.4404 (316L)
	Lid:	PC transparent or 1.4404 (316L)
	Seal between housing and lid:	EPDM, with lid PC Welded, with lid 1.4404 (316L)
	Nameplate:	Polyester film
	M12 plug (male):	Contacts CuZn, gold plated
	M12 plug (female):	See accessories
Valve plug (male):	Contacts CuZn, tin plated	
Valve plug (female):	Plug housing Polyamid Contacts CuZn, silver plated	
Ingress protection	Lid 1.4404 (316L), M12 plug:	Type 6P / IP69k
	Lid PC, M12 plug:	Type 4X / IP67
	Lid PC, Valve plug:	Type 4X / IP67
Sound level	max. 50 dBA	
Overall weight (ca.)	VN 7120:	0.17 kg (0.37 lbs)
	VN 7130 Pipe extension 1/2":	0.17 kg (0.37 lbs) + 0.9 kg/m (2.0 lbs per 39.3")
	VN 7130 Pipe extension 3/4":	0.17 kg (0.37 lbs) + 1.2 kg/m (2.6 lbs per 39.3")

All weights with 3/4" threaded process connection.

Transport and storage

Transport

Observe the instructions as stated on the transport packaging, otherwise the products may get damaged.

Transport temperature: -40 .. +80°C (-40 .. +176°F)

Transport humidity: 20 .. 85%

Transport incoming inspections must be carried out to check for possible transport damage.

Storage

Products must be stored at a dry and clean place. They must be protected from influence of corrosive environment, vibration and exposure to direct sunlight.

Storage temperature: -40 .. +80°C (-40 .. +176°F)

Storage humidity: 20 .. 85%

Operating conditions

Environment

Ambient and process temperature

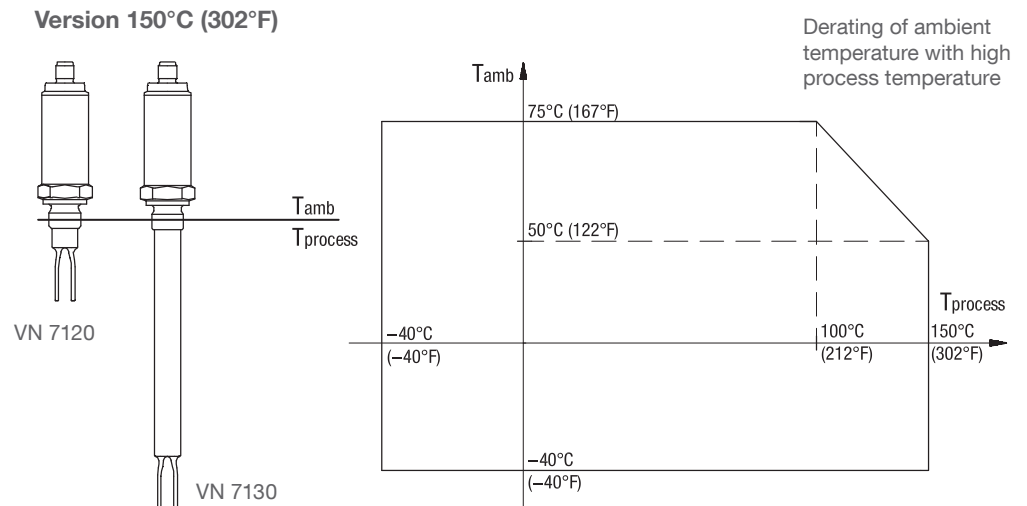
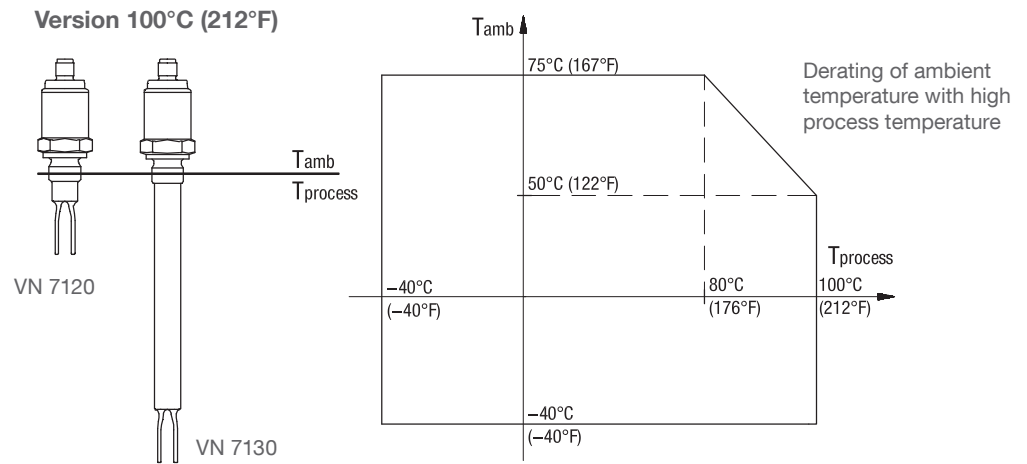

Operating conditions

Max. temperature for CIP and SIP 150°C (302°F), duration continuous. Unit de-energized

Max. permitted mechanical load

VN 7120

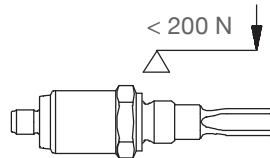

VN 7130

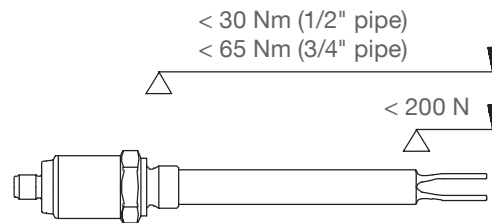

Rated values apply at 40°C

Max. process pressure -1 to 40 bar (-14.5 to 580 psi)
 -1 to 10 bar (-14.5 to 146 psi) for VN 7130 Pipe extension with sliding sleeve

Observe possible pressure limitation from the used flange type !

Vibration 1.5 (m/s²)/Hz according to EN 60068-2-64

Pollution degree 4

Relative Humidity 0 - 100%, suitable for outdoor use

Altitude max. 3.000 m (9.843 ft)

Ventilation Ventilation is not required

Expected product lifetime Following parameters have a negative influence on the expected product lifetime:
 High ambient- and process temperature, corrosive environment, high vibration, high flow of liquids with abrasive particles passing the probe.

Functional

Sensitivity Density 0,7 .. 2,5 g/cm³ (44 .. 156 lb/ft³) Optional 0,5 .. 2,5 g/cm³ (31 .. 156 lb/ft³)

Viscosity Dynamic viscosity, max. 10.000 mPa s (10.000 cP)

Switching point See drawing page 22

Non-repeatability +/- 1 mm (0.04"), DIN 61298-2

Approvals / Dimensions

Approvals

General Purpose * (Ordinary Locations)	CE UKCA usFMc
Overfill and leakage protection *, **	WHG
EMC	EN 61326
RoHS conform	According to directive 2011/65/EU
Hygiene *	EHEDG EL class I
Food grade material	Wetted parts with FDA registration. Details see "Mechanical data".
Pressure Equipment Directive (2014/68/EU)	As the equipment does not have pressure-bearing housings of its own, it is not subject to the PED: - as "pressure accessory" (see 2014/68/EU Art. 2 (5) and PED Guidelines A-08, A-40) - nor as "safety accessory" (see 2014/68/EU Art. 2 (4) and PED Guidelines A-20, A-25)

* Depending on selected version

** Relevant information for use in applications with WHG: see documentation "Technical Description"

Dimensions

All dimensions in mm (inch)

Plugs

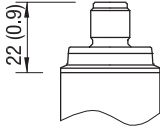
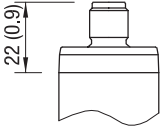
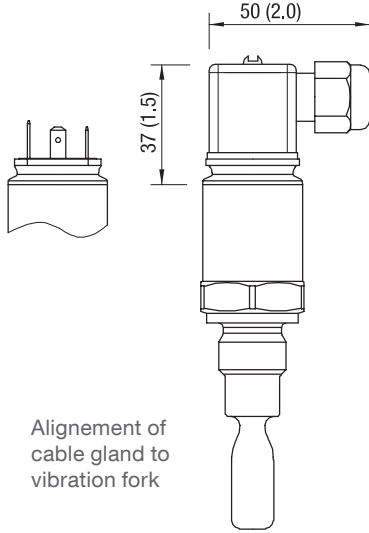
Plug	M12 with lid PC (transparent)	M12 with lid 1.4404 (316L)	Valve
Available for electronics	IO-Link 3-wire PNP	IO-Link 3-wire PNP	2-wire without contact 3-wire PNP
			

Dimensions

VN 7120 compact version

Thread

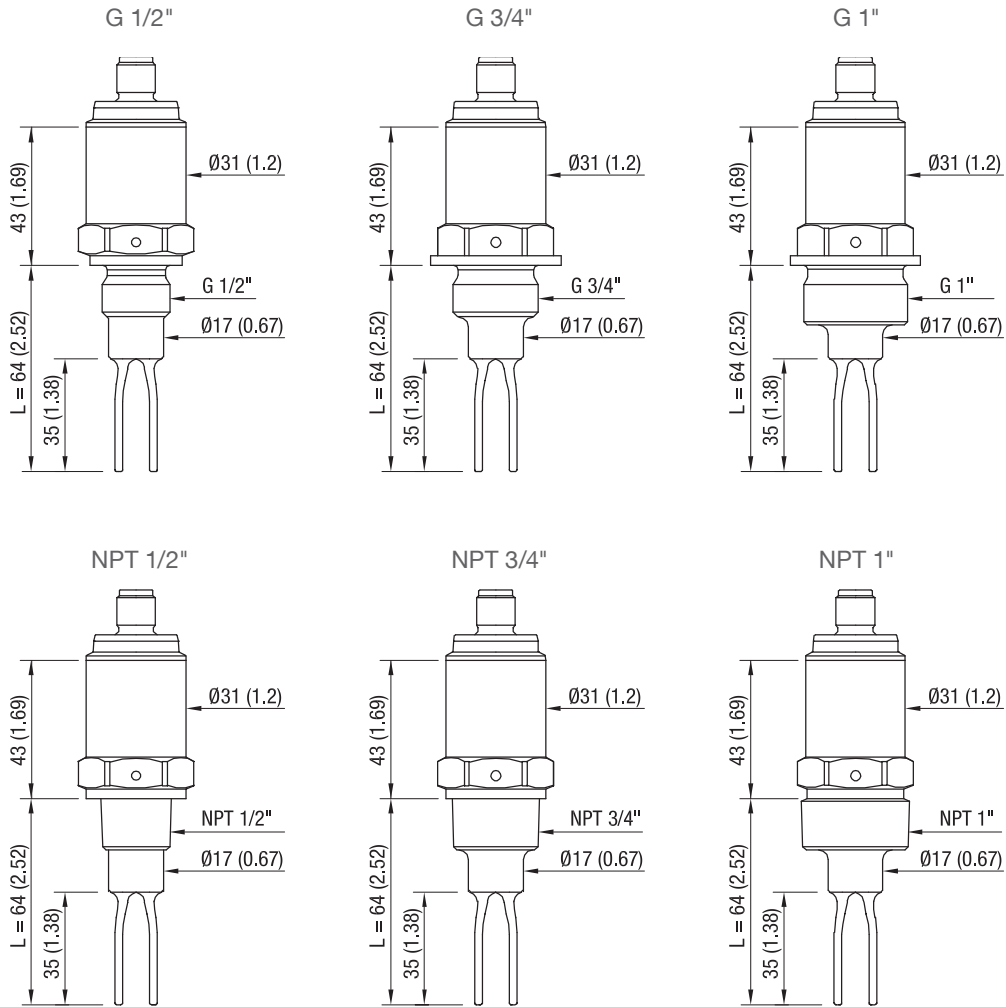

Stated versions 100°C (212°F)

Thread for hygiene adapter

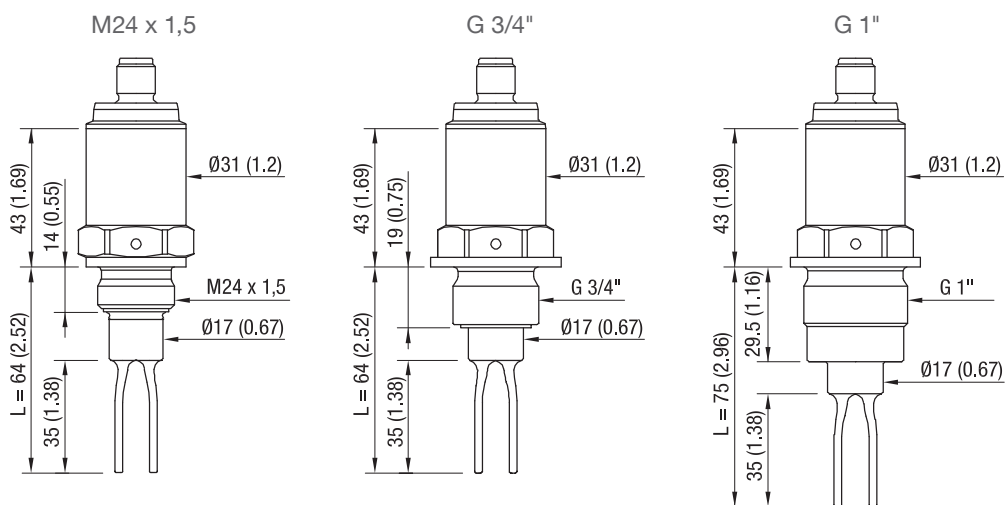

Stated versions 100°C (212°F)

Available with certificate EHEDG EL class I in combination with hygiene adapter

Dimensions

VN 7120 with elongated switchpoint

Thread

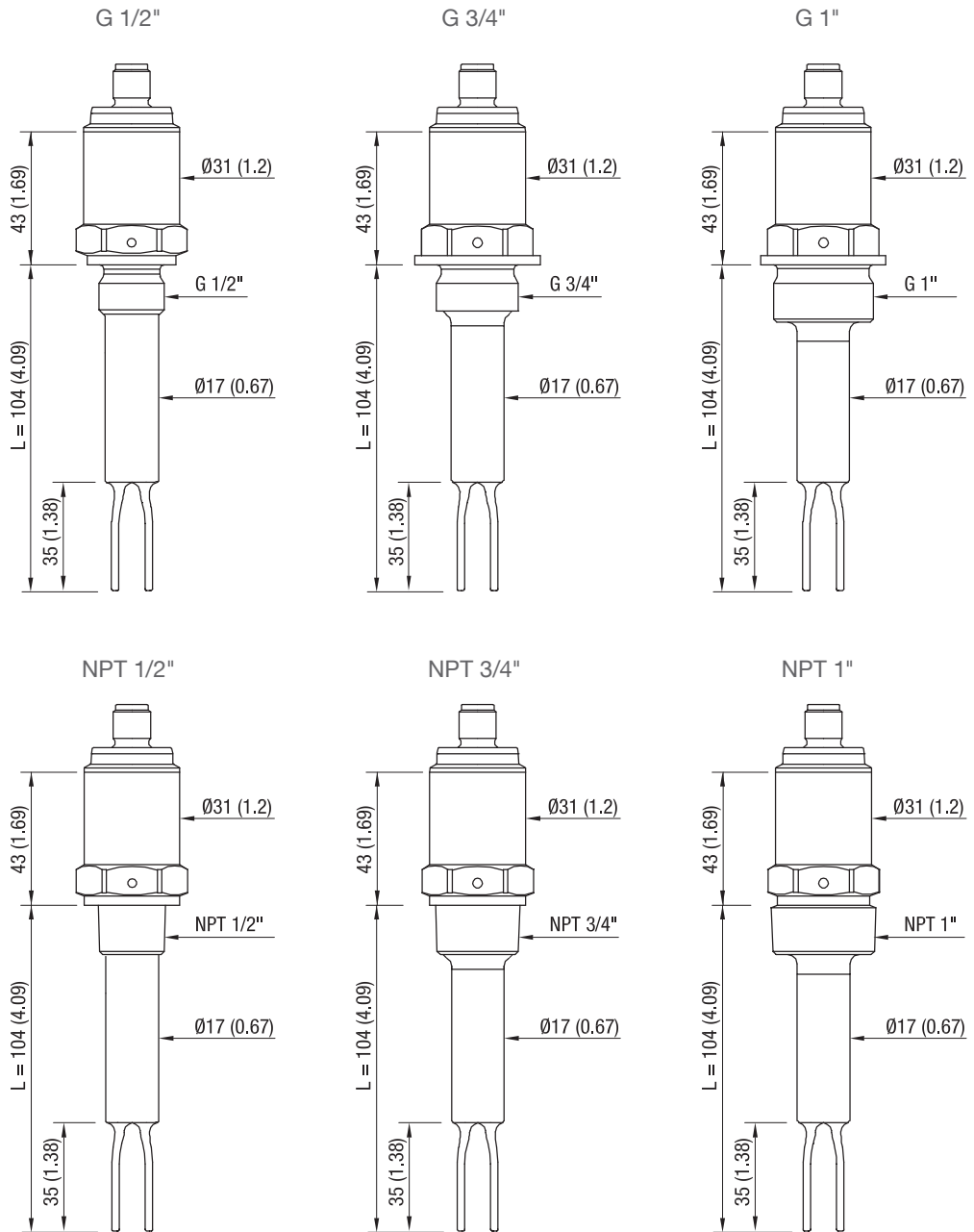

Stated versions 100°C (212°F)

Dimensions

VN 7120 with elongated switchpoint

Thread
for hygiene
adapter

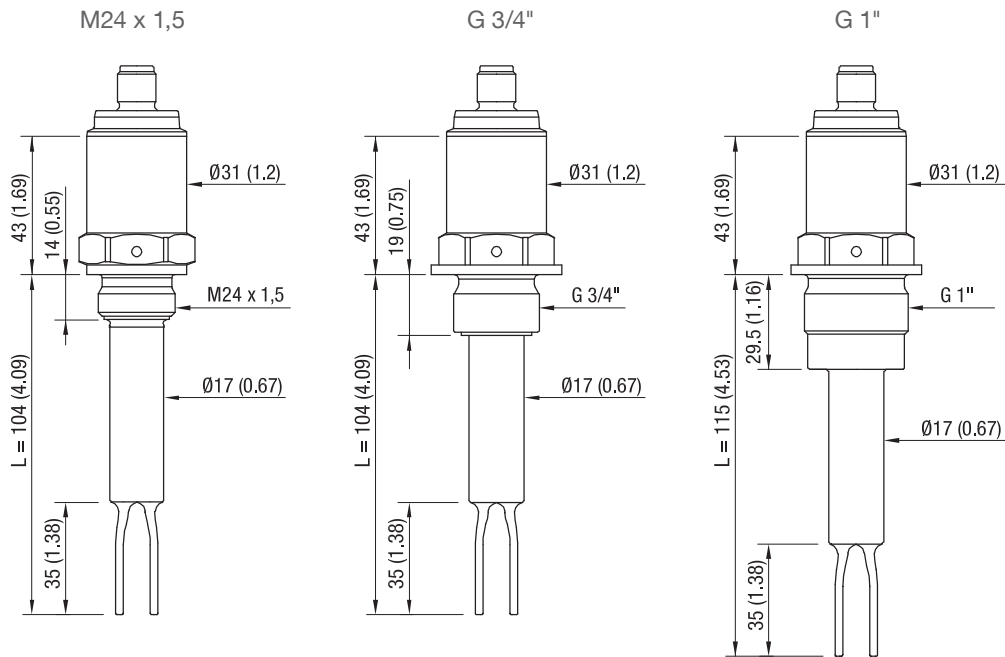

Stated versions 100°C (212°F)

Dimensions

VN 7130

Thread

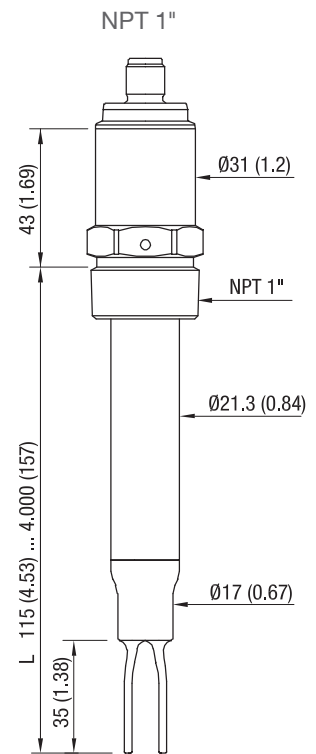
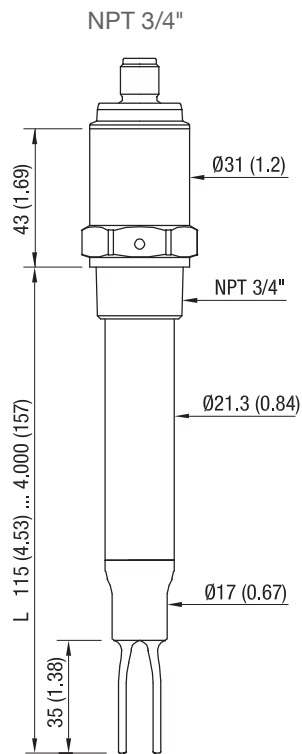
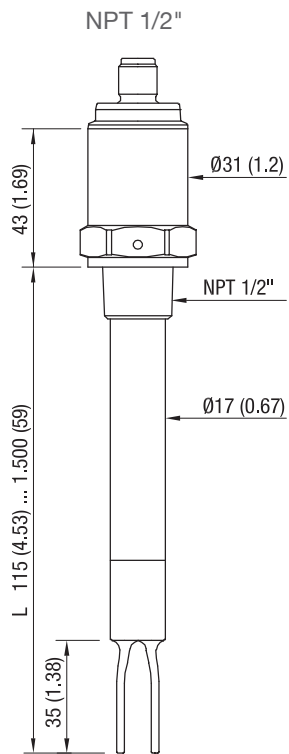
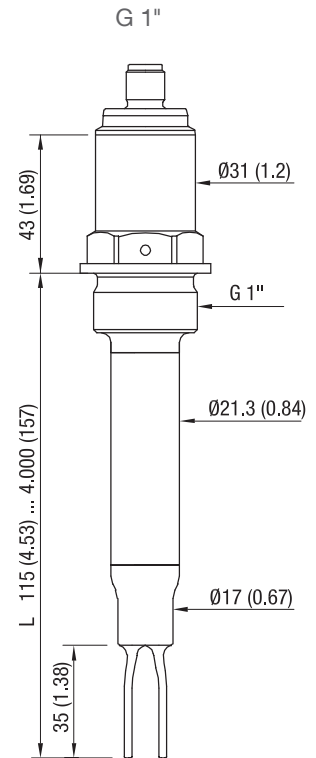
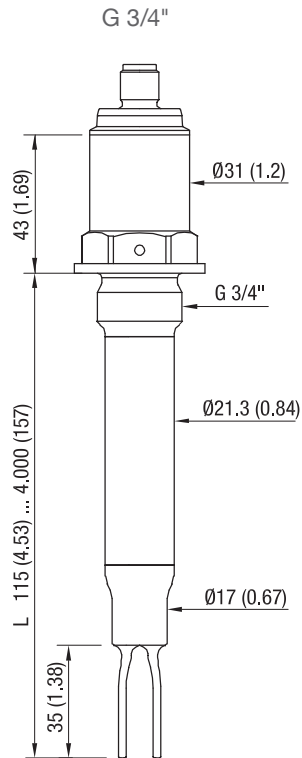
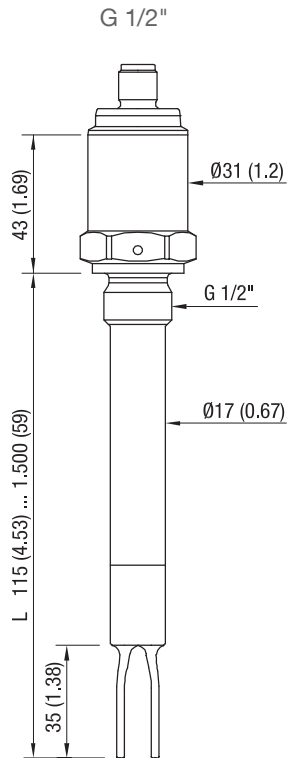

Stated versions 100°C (212°F)

Dimensions

VN 7130

Thread
for hygiene
adapter

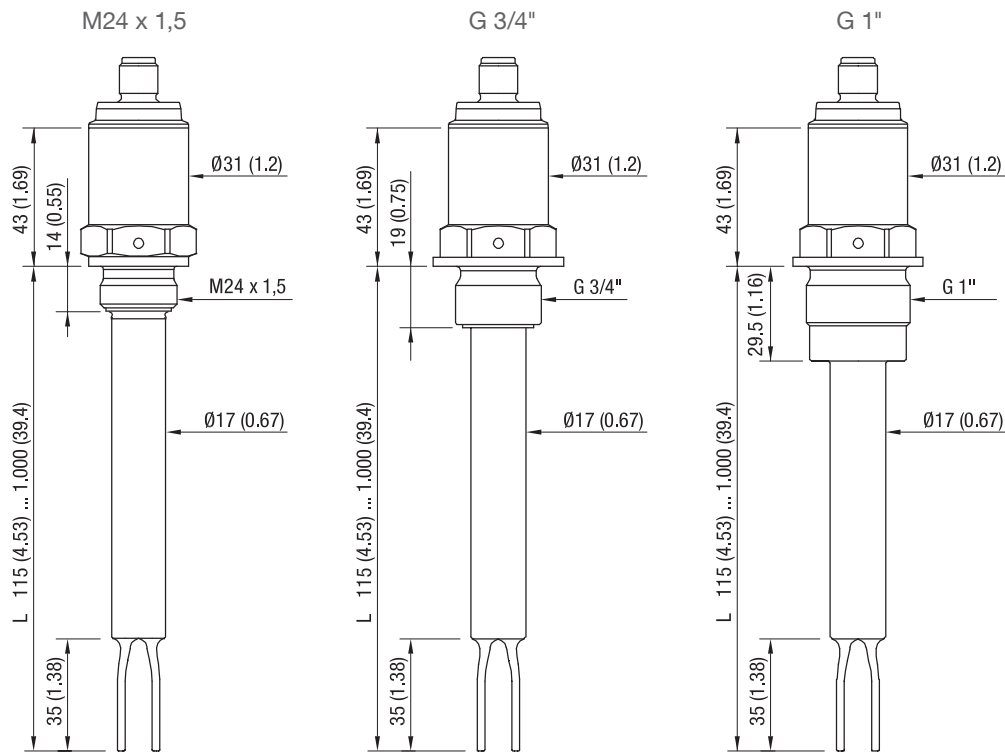

Stated version 100°C (212°F)
 Available with certificate EHEDG EL class I in combination with hygiene adapter

VN 7120 / VN 7130 Version 150°C (302°F)

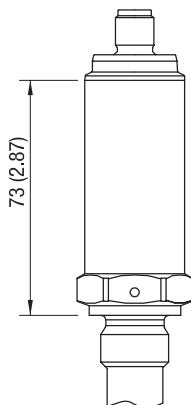

See VN 7120 and VN 7130 for:

- Dimensions not shown
- Various process connections

Dimensions

Flange

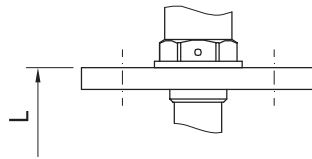

VN 7120 and VN7130
 Flange is screwed to
 G 3/4" thread process connection

	Code	Type	Number of holes	d2 mm (Inch)	Lk mm (Inch)	D mm (Inch)	T thickness mm (Inch)
ASME B16.5, raised face	R	1" 150 lbs	4	15,9 (0.63)	79,3 (3.12)	108,0 (4.25)	14,3 (0.56)
	S	1" 300 lbs	4	19,1 (0.75)	88,9 (3.5)	123,8 (4.87)	17,5 (0.69)
	T	1½" 150 lbs	4	15,9 (0.63)	98,6 (3.88)	127,0 (5.0)	17,5 (0.69)
	U	1½" 300 lbs	4	22,2 (0.87)	114,3 (4.5)	155,6 (6.13)	20,6 (0.81)
	V	2" 150 lbs	4	19,1 (0.75)	120,7 (4.75)	152,4 (6.01)	19,1 (0.75)
	W	2" 300 lbs	8	19,1 (0.75)	127,0 (5.0)	165,1 (6.5)	22,2 (0.87)
EN 1092-1 type A, flat faced	N	DN25 PN16/40	4	14,0 (0.55)	85,0 (3.35)	115,0 (4.53)	18,0 (0.71)
	P	DN40 PN16/40	4	18,0 (0.71)	110,0 (4.33)	150,0 (5.91)	18,0 (0.71)
	Q	DN50 PN16/25/40	4	18,0 (0.71)	125,0 (4.92)	165,0 (6.5)	18,0 (0.71)

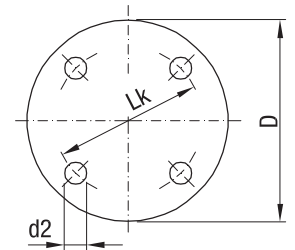

Raised face

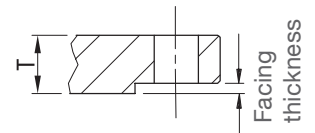

Type	Facing thickness
ASME 150 lbs ASME 300 lbs	2 mm (0.08")

Sliding sleeve VN 7130 (option)

G 1 1/4", G 1 1/2"; DIN ISO 228-1
 NPT 1 1/4", NPT 1 1/2"; ASME B 1.20.1
 Material: 1.4404 (316L)
 Sealing material to the extension pipe: FKM
 Max. process pressure: -1 to 10 bar (146 psi)

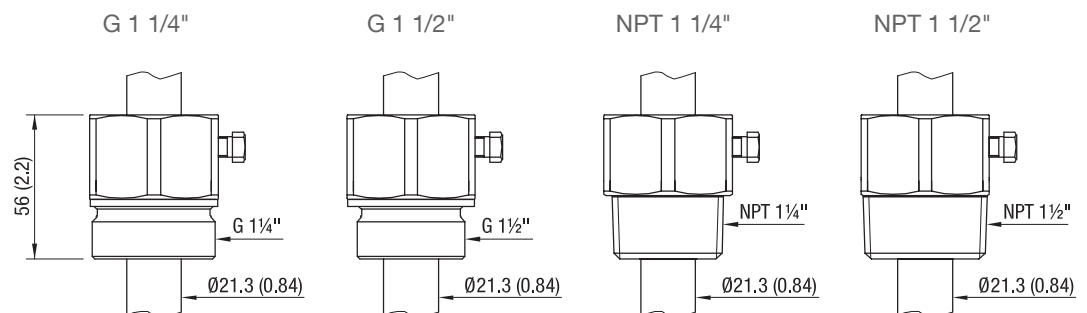

Mechanical installation

! General Safety Instructions

Process pressure	Improper installation may result in loss of process pressure. Observe possible pressure limitation from the used flange type or in case of use of the sliding sleeve (VN 7130).
Chemical resistance against the medium	Materials of construction are chosen based on their chemical compatibility (or inertness) for general purposes. For exposure to specific environments, check with chemical compatibility charts before installing.
Fastening of the threaded process connection	Mounting torque for the thread may not exceed 40 Nm (metal thread).. Use an open-end wrench. Do not fasten by turning the housing.
EHEDG approval/ Food grade material	The materials are available for the use under normal and predictable applications (according to directive 1935/2004 Art.3). Other conditions can influence the safety.

! General Mounting instructions

Handling precautions To prevent damage of the pipe extension, all VN 7130 units with a pipe longer than 2 m (6.5 ft), must be supported at these three points when lifting from a horizontal position.

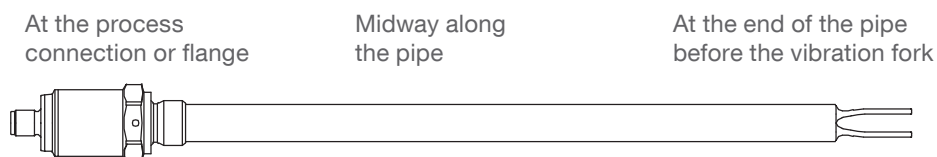

Sliding sleeve

Tighten the straining screw with 12 Nm to obtain resistance against pressure

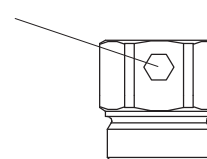

Sealing Ensure proper seal of the process connection thread in case of process pressure.

Hygienic process connection Observe relevant instruction requirements, see page 24.

Mechanical installation

Mounting instructions

VN 7120

CAUTION

- Alignment of the fork must be in flow direction of the liquid (see page 23)
- Distance to material flow (filling) must be observed
- Max. permitted mechanical load (see page 10) must be observed

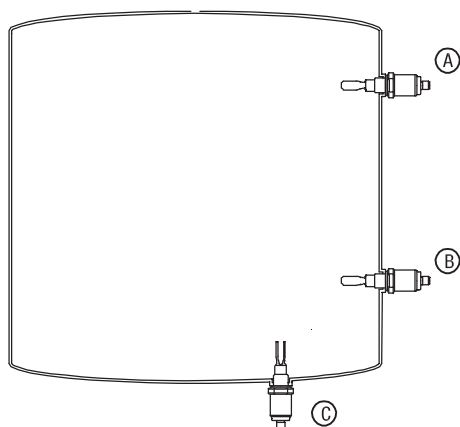

Vertical vessel

- A** Full detector horizontal
- B** Demand or empty detector horizontal
- C** Empty detector vertical from the bottom

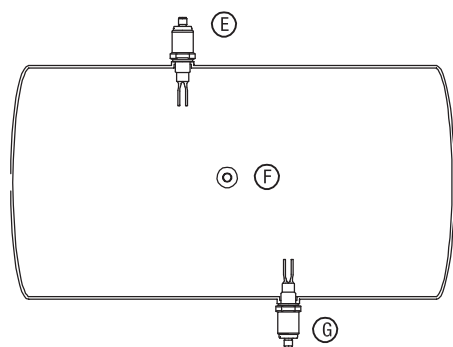

Horizontal vessel

- E** Full detector vertical
- F** Demand or empty detector horizontal
- G** Empty detector vertical from the bottom

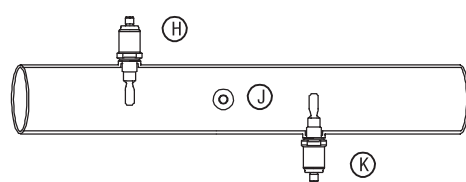

Horizontal pipe

- H** Full detector vertical
- J** Demand or empty detector horizontal
- K** Empty detector vertical from the bottom

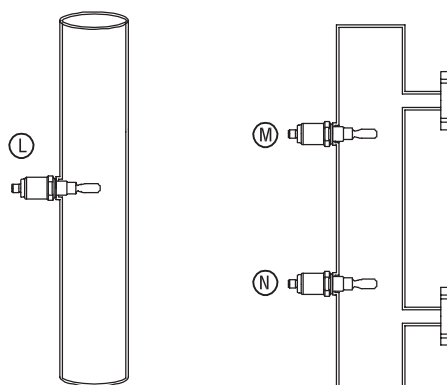

Vertical pipe

- L** Full, demand or empty detector horizontal

Bypass

- M** Full detector horizontal
- N** Demand or empty detector horizontal

Mechanical installation

VN 7130

CAUTION

- Alignment of the fork must be in flow direction of the liquid (see page 23)
- Distance to material flow (filling) must be observed
- Max. permitted mechanical load (see page 10) must be observed

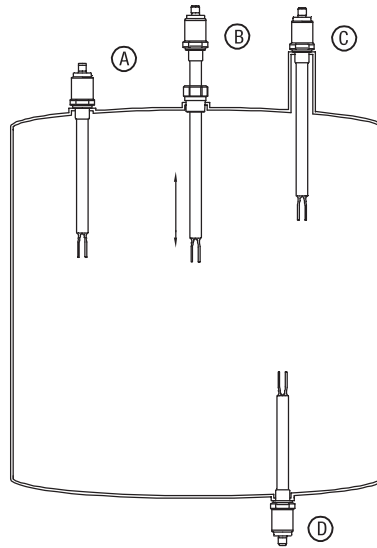

Vertical vessel

Full, demand or empty detector:

- A** Vertical
- B** Vertical with sliding sleeve
- C** Vertical with long mounting socket
- D** Vertical from bottom

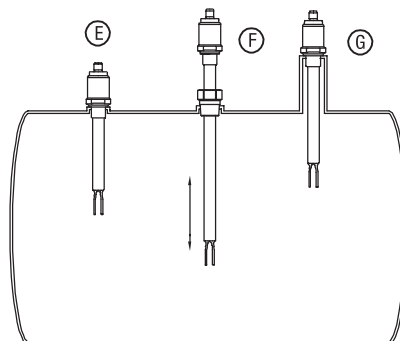

Horizontal vessel

- E** Full, demand or empty detector vertical
- F** Vertical with sliding sleeve
- G** Vertical with long mounting socket

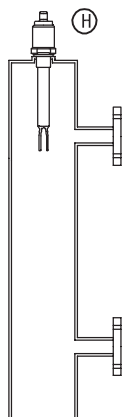

Bypass

- H** Full, demand or empty detector vertical

Mechanical installation

Switch point

Vertical installation,
top mounting

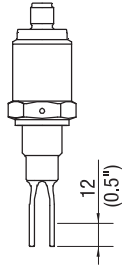

Vertical installation,
bottom mounting

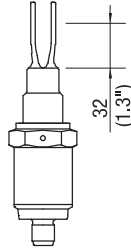

Horizontal installation

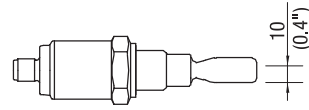

Switchpoint is stated for water at 25°C (77°F)

Distance to vessel wall and pipe wall

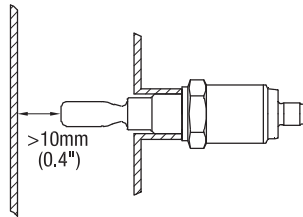

Observe min. distance of vibration fork to vessel wall and pipe wall

Horizontal installation

General

CORRECT
Narrow side of the vibration fork faces vertically

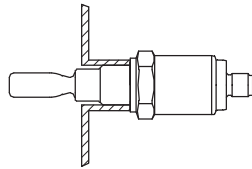

WRONG
Wide side of the vibration fork faces vertically. Liquid may not drip off.

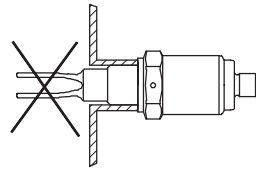

Liquid with low viscosity

CORRECT
Vibration fork located outside nozzle

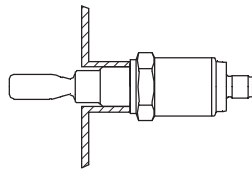

CORRECT
Vibration fork located inside nozzle. Low viscosity liquid flows out of the nozzle. Observe min. nozzle diameter.

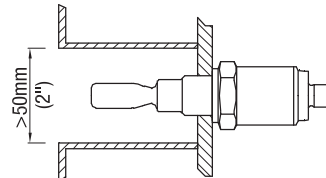

Liquid with high viscosity

CORRECT
Vibration fork located outside nozzle

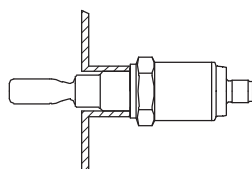

WRONG
Vibration fork located inside nozzle. High viscosity liquid may remain inside nozzle.

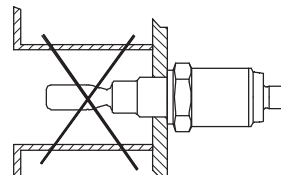

Mechanical installation

Mounting in pipes

CORRECT
Narrow side of the vibration fork aligns with the direction of the liquid flow

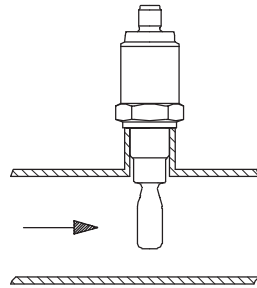

WRONG
Wide side of the vibration fork aligns with the direction of the liquid flow. Fork may be overloaded, liquid may be swirled.

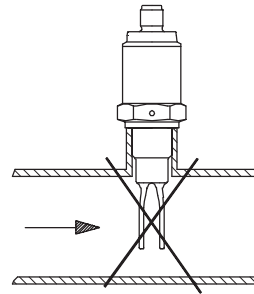

Orientation marking of vibration fork

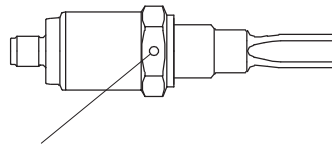

Orientation marking shows the orientation of the vibration fork after mounting

Electrical installation

! General Safety Instructions

Handling	In the case of inexpert handling or handling malpractice the electric safety of the device cannot be guaranteed.
Installation regulations	The local regulations or VDE 0100 (Regulations of German Electro technical Engineers) must be observed.
Power supply switch	A power-supply-disconnecting switch must be provided and marked near the device.
Wiring diagram	The electrical connections have to be made according to the wiring diagram.
Supply voltage	<p>Compare the supply voltage applied with the specifications given on the name plate before switching the device on.</p> <p>The unit must be supplied from a SELV source providing electrical isolation between the input and output, in order to meet the applicable safety requirements of IEC 61010-1.</p> <p>Observe reduced supply voltage ratings in wet locations. A wet location is a location where water or other conductive liquid may be present and is likely to increase the risk of electric shock.</p>
M12 mating plug and Field wiring cables	<p>With use of M12 plug: The mating plug must have following specifications</p> <ul style="list-style-type: none"> • M12x1 according to IEC 61076-2-101, female, 4-pole, coding A-standard • Ingress protection IP68 • The temperature rating must be at least 10 K above max. ambient temperature and 10K below min. ambient temperature. <p>The field wiring cables must have following specifications:</p> <ul style="list-style-type: none"> • The diameter and cross section has to match to the specification of the mating plug. • The temperature rating must be at least 10 K above max. ambient temperature and 10K below min. ambient temperature. • Install the field wiring cables according to the instructions of the mating plug
Signal output protection	Provide protection for signal output to protect against spikes with inductive loads (e.g. when connecting external relays).
Protection against static charging	The unit must be earthed in any case to avoid static charging of the unit, especially on applications with pneumatic conveying. Functional earthing by the process connection is satisfactory.

Electrical installation

IO-Link

Wiring diagram

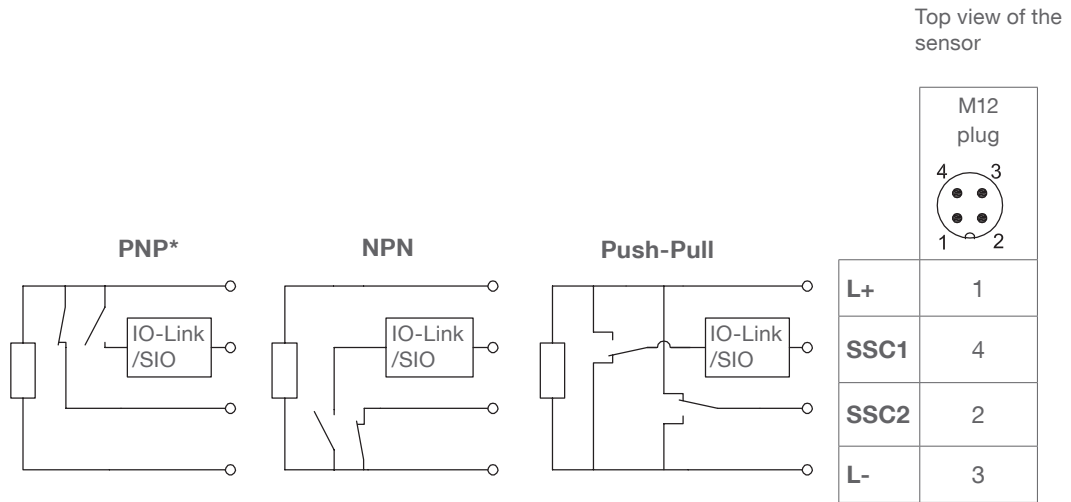

*Factory setting
 Change to NPN or Push-Pull can be done in IO-Link registers.
 External fuse in L+: max. 0,5A, fast or slow, HBC, 250V

Output logic and LED's

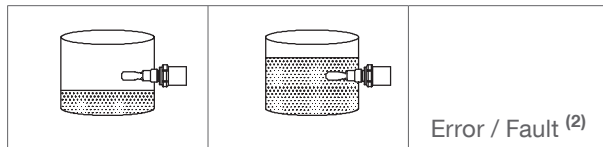

SSC1 ⁽¹⁾	FSL	PNP/NPN			
	Push-Pull				
SSC2 ⁽¹⁾	FSH	PNP/NPN			
	Push-Pull				

LED on transparent lid ⁽³⁾

	Green			
	Yellow			
	Red			

LED's on M12 connector ⁽⁴⁾

	Green (Power)			
	Yellow (SSC1)			
	Yellow (SSC2)			
	Red (Failure)	—	—	—

Electrical installation

- (1) SSC1 and SSC2
Factory setting:
SSC1 is set to FSL and PNP.
SSC2 is set to FSH and PNP.
Settings can be changed in IO-Link registers.
FSL = Fail safe low. Contact opens in case of uncovered vibration fork (safe state).
FSH = Fail safe high. Contact opens in case of covered vibration fork (safe state).
- (2) Error / Fault:
The stated output logic (safe state, open contacts) is present in case of Fault (unit defect).
In case of Error (remediable), the outputs go to safe state (open contacts) and recover after the Error is cleared.
- (3) LED on transparent lid:
The internal LED is visible on the transparent lid.
Yellow LED is ON in case of covered vibration fork.
Note: This concept is used for all VN7 devices with M12 plug.
Red LED Flashing: Error remediable:
Output current overload, incorrect wiring, too high temperature, testmagnet too long present
Red LED ON: Fault, unit defect
- (4) LED's on M12 connector:
For devices with 316L lid, internal LED is not present, instead LED's on M12 connector are used.
The stated colours (green, yellow) are typically used in M12 connectors, check datasheet of used connector.
Yellow LEDs are ON in case of closed SSC1 and SSC2 contacts (dependent on FSL/FSH setting).
Red LED is not present.

Electrical installation

3-wire PNP with M12 plug

Wiring diagram

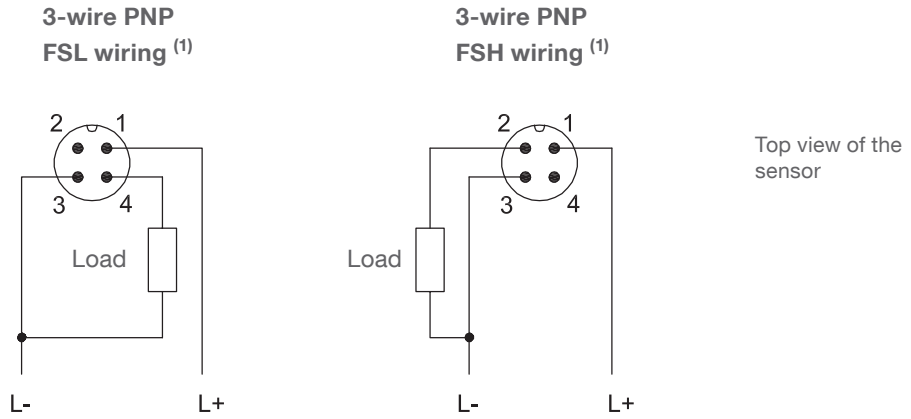

Connect either as FSL wiring or as FSH wiring, depending on required output logic (see below)
 If required, both outputs (pin 2 and pin 4) can be connected (antivalent).
 External fuse in L+: max. 0,5A, fast or slow, HBC, 250V

Output logic and LED's

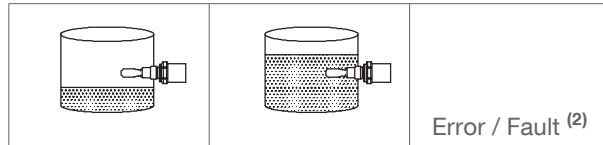

FSL wiring ⁽¹⁾	1 — 4	1 — 4	1 — 4
FSH wiring ⁽¹⁾	1 — 2	1 — 2	1 — 2

LED on transparent lid ⁽³⁾

	Green	☀	●	●
	Yellow	●	☀	●
	Red	●	●	☀

LED's on M12 connector ⁽⁴⁾

	Green (Power)	☀	☀	☀
	Yellow (Pin 4)	●	☀	●
	Yellow (Pin 2)	☀	●	●
	Red	—	—	—

Electrical installation

- (1) FSL = Fail safe low. Contact opens in case of uncovered vibration fork (safe state).
FSH = Fail safe high. Contact opens in case of covered vibration fork (safe state).

- (2) Error / Fault:
The stated output logic (safe state, open contacts) is present in case of Fault (unit defect).
In case of Error (remediable), the outputs go to safe state (open contacts) and recover after the Error is cleared.

- (3) LED on transparent lid:
The internal LED is visible on the transparent lid.
Yellow LED is ON in case of covered vibration fork.
Note: This concept is used for all VN7 devices with M12 plug.
Red LED Flashing: Error remediable:
Output current overload, incorrect wiring, too high temperature, testmagnet too long present
Red LED ON: Fault, unit defect

- (4) LED's on M12 connector:
For devices with 316L lid, internal LED is not present, instead LED's on M12 connector are used.
The stated colours (green, yellow) are typically used in M12 connectors, check datasheet of used connector.
Yellow LED's are ON in case of closed Pin 4 and Pin 2 contacts (dependent on FSL/FSH setting).
Red LED is not present.

Electrical installation

3-wire PNP with Valve plug

Wiring diagram

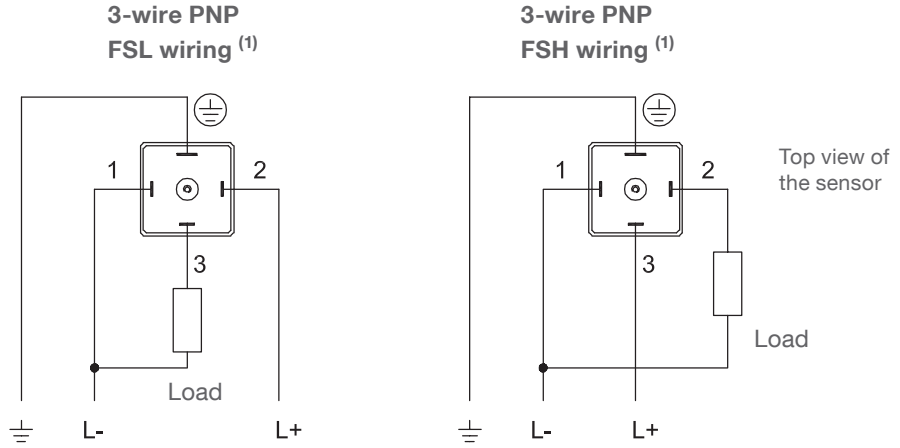

Connect either as FSL wiring or as FSH wiring, depending on required output logic (see below)
 External fuse in L+: max. 0,5A, fast or slow, HBC, 250V

Output logic and LED's

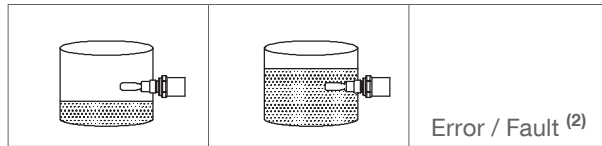

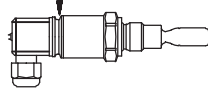
FSL wiring (1)		3 — 2	3 — 2	3 — 2
	Green	☀	●	●
	Yellow	●	☀	●
	Red	●	●	☀ ☀

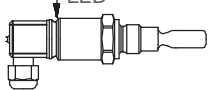
FSH wiring (1)		2 — 3	2 — 3	2 — 3
	Green	●	☀	●
	Yellow	☀	●	●
	Red	●	●	☀ ☀

Electrical installation

- (1) FSL = Fail safe low. Contact opens in case of uncovered vibration fork (safe state).
FSH = Fail safe high. Contact opens in case of covered vibration fork (safe state).

- (2) Error / Fault:
The stated output logic (safe state, open contacts) is present in case of Fault (unit defect).
In case of Error (remediable), the outputs go to safe state (open contacts) and recover after the Error is cleared.

- (3) LED:
The internal LED is visible on the transparent lid.
Yellow LED is ON in case of closed contact.
Note: This concept is used for all VN7 devices with Valve plug.
Red LED Flashing: Error remediable:
Output current overload, incorrect wiring, too high temperature, testmagnet too long present
Red LED ON: Fault, unit defect

Electrical installation

2-wire without contact

Wiring diagram

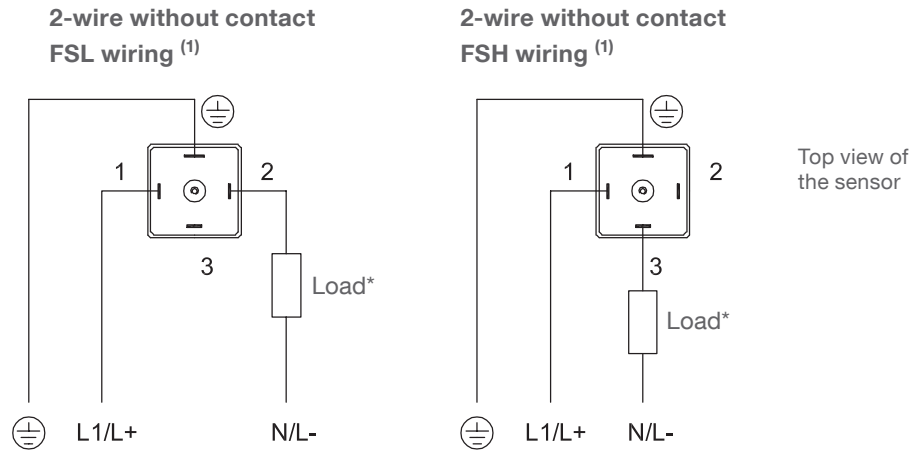







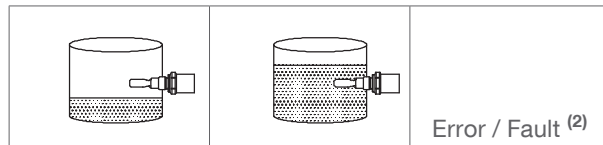

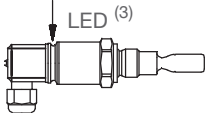









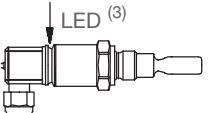

Connect either as FSL wiring or as FSH wiring, depending on required output logic (see below)
 External fuse in L1/L+: max. 0,5A, fast or slow, HBC, 250V

* Provide protection against spikes with inductive loads (e.g. relay)

Output logic and LED's



FSL wiring ⁽¹⁾		1 — 2	1 — 2	1 — 2
	Green			
	Yellow			
	Red			

FSH wiring ⁽¹⁾		1 — 3	1 — 3	1 — 3
	Green			
	Yellow			
	Red			

Electrical installation

- (1) FSL = Fail safe low. Contact opens in case of uncovered sensor (safe state).
FSH = Fail safe high. Contact opens in case of covered sensor (safe state).

- (2) Error / Fault:
The stated output logic (safe state, open contacts) is present in case of Fault (unit defect).
In case of Error (remediable), the outputs go to safe state (open contacts) and recover after the Error is cleared.

- (3) LED:
The internal LED is visible on the transparent lid.
Yellow LED is ON in case of closed contact.
Note: This concept is used for all VN7 devices with Valve plug.
Red LED Flashing: Error remediable:
Output current overload, short circuit, too high temperature, testmagnet too long present
Red LED ON: Fault, unit defect

Operation

Commissioning

Install according to chapters "Electrical installation" and "Mechanical installation".
Apply power supply.
LED indicate the actual output situation.
No setting on site is required.

WHG Proof Test

The implementation of the WHG proof test is done in accordance with the documentation "Technical Description" for WHG, Annex 8, Proof Test, by following possibilities:

- Filling the vessel until the switchpoint is reached and monitoring the correct reaction of the system
- Suitable simulation of the level or of the physical measurement effect. This can be done for example by dismounting the sensor and immersion into the original medium.

Test with Test magnet

Bring the test magnet to the marking at the enclosure and monitor, if a correct change from uncovered to covered or from covered to uncovered happens:

- LED must change from green to yellow or from yellow to green
- Signal output must change from closed to open or from open to close

Note:

This test does not proof if the unit is sensitive enough to measure the material of the application.

Operation with IO-Link

IO-Link Data

Communication interface	IO-Link, IEC 61131-9, SDCI standard
IO-Link Specification	1.1.3
IO-Link Profiles	Smart Sensor Profile 2nd Edition, version 1.1
Required IO-Link master	as per DIN EN 61131-9
Speed	COM2 (38,4 kBaud)
Min. process cycle time	13.2 ms
Process data width	16 bit
IO-Link data storage	yes
Block parameter	no
SIO-Mode	yes

Abbreviations

ISDU = Indexed Service Data Unit

R/W = read/write

TP = Teachpoint = "Actual measured value" in % present at the time when any of the System Commands "Teach" is actuated and which is used to set SP1 and/or SP 2

SP1 = Setpoint 1

SP2 = Setpoint 2

SSC1 = Switching Signal Channel 1

SSC2 = Switching Signal Channel 2

FSL = Fail safe Low

FSH = Fail safe High

IO-Link Registers

Process Data (PDE - Process Data Exchange)

Bit 0 (LSB) to Bit 13 (MSB)	Bit 14	Bit 15
Actual measured value*: 0,0% - 120,0% Resolution 0,1%	SSC1	SSC2

Data Type: ulnteger

SSC1 / SSC2:

Active = contact closed

Inactive = contact open

Pin assignement with PNP,
 NPN, Push-Pull: see page 26



* Relates to the resonance frequency of the vibration fork:
 0% relates to covered vibration fork in high density material.
 100% relates to uncovered vibration fork (vibration in air).

! In application with overfill approval (WHG) the use of IO-Link is applicable for setting registers only. The "Process data Exchange" is not allowed, instead the signal output (PNP, NPN) must be used.

Operation with IO-Link

Item	ISDU (dec)	Access	Length (byte)	Data type	Value Range	Default value
------	------------	--------	---------------	-----------	-------------	---------------

IO-Link specific device data

System Command	2	W	1	UInt	See "System Commands"	
Vendor ID	7-8	R	2	UInt		1554
Device ID	9-11	R	4	UInt		101
Vendor Name	16	R	64	String		UWT GmbH
Product Name	18	R	64	String		VN 71*0
Product Text	20	R	64	String		Vibration level limit switch
Order code	160	R	64	String		
Serial number	21	R	16	String		
Hardware Revision	22	R	2	String		
Firmware Revision	23	R	5	String		
Application-specific Tag	24	R/W	32	String		***
Function Tag	25	R/W	32	String		
Location Tag	26	R/W	32	String		
Device status	36	R	1	UInt	0 = Device is operating properly 3 = Functional-check 4 = Failure	0
Detailed Device Status	37	R	4 x 3	String		
Process Data Input	40	R	2	UInt	Values same as Process Data (PDE)	

System Commands

System Command ISDU (dec)	Name	Description
65	Teach SP1 (Teach-in Single Value)	"Teach SP1" is used to set SP1 to the "Actual measured value" (in %) for the output as selected in register 58. When teaching, the vibration fork must be partly covered with the liquid to be taught, as stated in page 22 "switch point".
66	Teach SP2 (Teach-in Single Value)	"Teach SP2" is used to set SP2 to the "Actual measured value" (in %) for the output as selected in register 58. When teaching, the vibration fork must be partly covered with the liquid to be taught, as stated in page 22 "switch point".
67	Teach SP1 TP1 (Teach-in Two Value)	In case the user requires to set SP1 to the average of two Teachpoints TP1 and TP2, then first "Teach SP1 TP1" is actuated, afterwards "Teach SP1 TP2" must be actuated.
68	Teach SP1 TP2 (Teach-in Two Value)	See explanation on "Teach SP1 TP1".
69	Teach SP2 TP1 (Teach-in Two Value)	In case the user requires to set SP2 to the average of two Teachpoints TP1 and TP2, then first "Teach SP2 TP1" is actuated, afterwards "Teach SP2 TP2" must be actuated.
70	Teach SP2 TP2 (Teach-in Two Value)	See explanation on "Teach SP2 TP1".
79	Teach Cancel (Teach-in Two Value)	In case "Teach SP1 TP1" was actuated and "Teach SP1 TP2" shall not proceed, this command cancels the actuated command "Teach SP1 TP1".
129	Application Reset	Interrupts shortly the connection to the IO-Link Master.
130	Restore factory settings	Sets all stated registers to "Default value".
131	Back-to-box	Disconnects communication from the IO-Link master and sets all stated registers to "Default value".
160	Switchpoints Reset	Sets registers 60, 62 to "Default values".

Operation with IO-Link

Item	ISDU (dec)	Subindex	Access	Length (byte)	Data type	Value range	Default value
------	------------	----------	--------	---------------	-----------	-------------	---------------

UWT specific device data

Switching Signal Channel 1: *

SSC1 Parameter	60	0	R/W	8	Int		
SSC1 Param - SP1		1	R/W	4	Int	0.0% - 100.0% Resolution 0.1%	75% **
SSC1 Param - SP2		2	R/W	4	Int	0.0% - 100.0% Resolution 0.1%	80% **
SSC1 Configuration	61	0	R/W	6	UInt		
SSC1 Config - Logic		1	R/W	1	UInt	0 = FSL 1 = FSH	FSL
SSC1 Config -Mode		2	R/W	1	UInt	0 = Deactivated 1 = Single Point 2 = Window 3 = Two Point	3
SSC1 Config -Hyst		3	R/W	4	Int	0.0% - 100.0% Resolution 0.1%	5%
SSC1 Config -Type	64	0	R/W	1	UInt	0 = Push-Pull 1 = NPN 2 = PNP	PNP
SSC1 Param - Delay 1 (uncovered to covered)	68	0	R/W	2	UInt	3 ... 600 (equates to 0.3 - 60 sec)	0.5 sec
SSC1 Param - Delay 2 (covered to uncovered)	69	0	R/W	2	UInt	3 ... 600 (equates to 0.3 - 60 sec)	1.0 sec

Switching Signal Channel 2: *

SSC2 Parameter	62	0	R/W	8	Int		
SSC2 Param - SP1		1	R/W	4	Int	0.0% - 100.0% Resolution 0.1%	75% **
SSC2 Param - SP2		2	R/W	4	Int	0.0% - 100.0% Resolution 0.1%	80% **
SSC2 Configuration	63	0	R/W	6	UInt		
SSC2 Config - Logic		1	R/W	1	UInt	0 = FSL 1 = FSH	1
SSC2 Config -Mode		2	R/W	1	UInt	0 = Deactivated 1 = Single Point 2 = Window 3 = Two Point	3
SSC2 Config -Hyst		3	R/W	4	Int	0.0% - 100.0% Resolution 0.1%	5%
SSC2 Config -Type	80	0	R/W	1	UInt	0 = Push-Pull 1 = NPN 2 = PNP	PNP
SSC2 Param - Delay 1 (uncovered to covered)	84	0	R/W	2	UInt	3 ... 600 (equates to 0.3 - 60 sec)	0.5 sec
SSC2 Param - Delay 2 (covered to uncovered)	85	0	R/W	2	UInt	3 ... 600 (equates to 0.3 - 60 sec)	1.0 sec

* Explanation of Switchpoint setting see page 40-41

** Factory setted values for switchpoints (register 60 and 62 "Default value") fit to measurement of water

Operation with IO-Link

Item	ISDU (dec)	Subindex	Access	Length (byte)	Data type	Value range	Default value
------	------------	----------	--------	---------------	-----------	-------------	---------------

UWT specific device data

Teach-in Methods:

TeachSelect	58	0	R/W	1	UInt	1 = SSC1 2 = SSC2 255 = All SSC	255
TeachResult	59	0	R	1	UInt		
State		1	R	4 bit	UInt	0 = IDLE 1 = SUCCESS 2 = SUCCESS 3 = SUCCESS 4 = WAIT FOR COMMAND 5 = BUSY 7 = ERROR	0
Flag SP1 TP1		2	R	1 bit	BooleanT	0 = Initial or not ok 1 = OK	0
Flag SP1 TP2		3	R	1 bit	BooleanT	0 = Initial or not ok 1 = OK	0
Flag SP2 TP1		4	R	1 bit	BooleanT	0 = Initial or not ok 1 = OK	0
Flag SP2 TP2		5	R	1 bit	BooleanT	0 = Initial or not ok 1 = OK	0

See as well notes on System command

Operation with IO-Link

Item	ISDU (dec)	Access	Length (byte)	Data type	Value range	Default value
------	------------	--------	---------------	-----------	-------------	---------------

UWT specific device data

LED's:

LED: SSC1 inactive + SSC2 inactive	96	R/W	1	UInt	0 = Red 1 = Yellow 2 = Green 3 = Blue 4 = Purple 5 = White 6 = Off	2
LED: SSC1 inactive + SSC2 active	97	R/W	1	UInt	0 = Red 1 = Yellow 2 = Green 3 = Blue 4 = Purple 5 = White 6 = Off	2
LED: SSC1 active + SSC2 inactive	98	R/W	1	UInt	0 = Red 1 = Yellow 2 = Green 3 = Blue 4 = Purple 5 = White 6 = Off	1
LED: SSC1 active + SSC2 active	99	R/W	1	UInt	0 = Red 1 = Yellow 2 = Green 3 = Blue 4 = Purple 5 = White 6 = Off	1
LED: Failure	100	R/W	1	UInt	0 = Red 1 = Yellow 2 = Green 3 = Blue 4 = Purple 5 = White 6 = Off	0

Diagnostics:

Operating time	128	R	4	UInt	0 ... 2 ³² hours	0
Temperature electronic* actual	131	R	1	Int	-128 ... +127 °C	
Temperature electronic* min.	132	R	1	Int	-128 ... +127 °C	
Temperature electronic* max.	133	R	1	Int	-128 ... +127 °C	
SSC1 Diag - Functional check	70	R/W	1	UInt	0 = No functional-check 1 = Simulate SSC1 active 2 = Simulate SSC1 inactive	0
SSC2 Diag - Functional check	86	R/W	1	UInt	0 = No functional-check 1 = Simulate SSC2 active 2 = Simulate SSC2 inactive	0

* Ambient temperature of the electronic inside the enclosure (outside process)

Operation with IO-Link

Config mode (IO-Link register 61 and 63)

Two point mode (default)

Switchpoints of SSC1 and SSC2 are set by registers SP1 and SP2

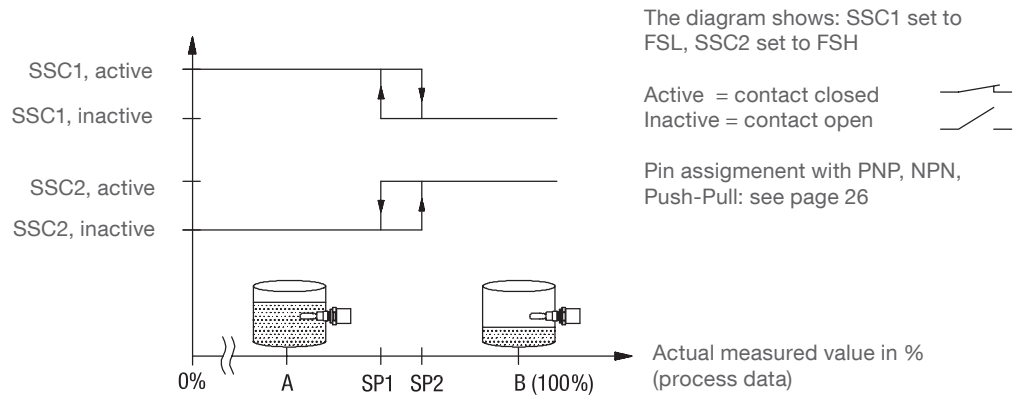

- A Covered vibration fork
- B Uncovered vibration fork (vibration in air)

Note: The values SP1, SP2 can be set independent for SSC1 and SSC2. See registers 60 and 62.

Single point mode (special application)

Switchpoints of SSC1 and SSC2 are set by registers SP1 and Hysteresis

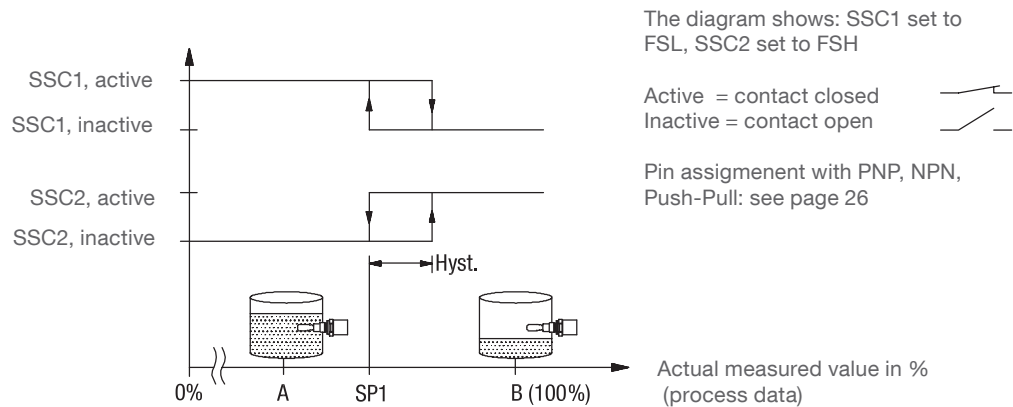

- A Covered vibration fork
- B Uncovered vibration fork (vibration in air)

Example: With SP1 = 75% and Hysteresis = 5% the output changes at 75% and 80%

Note: The values SP1, Hysteresis can be set independent for SSC1 and SSC2. See registers 60 and 62. SP2 is not effective.

Operation with IO-Link

Window mode (special application)

Switchpoint of SSC1 and SSC2 are set by registers SP1, SP2 and Hysteresis

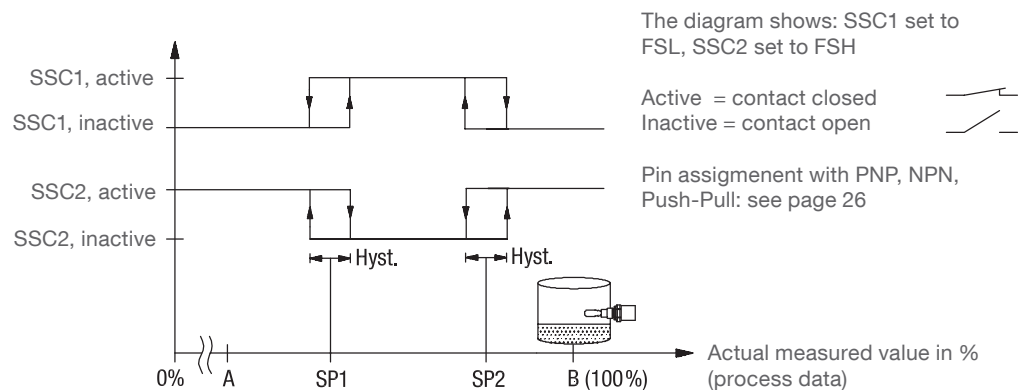

- A Used for special application if required (output indicates uncovered)
- B Uncovered vibration fork (vibration in air)

Example: With SP1 = 70%, SP2 = 80%, Hysteresis = 5%:
 The output changes at 68,5% and 72,5% (related to SP1) and at 78,5% and 82,5% (related to SP2)

Note: The values SP1, SP2, Hysteresis can be set independent for SSC1 and SSC2. See registers 60 and 62.

Troubleshooting

LED *	Behaviour	Cause	Action
OFF		Proper power not applied to device. Connector came loose. Unit is defect.	Check supply voltage. Refasten connector. Contact distributor.
Green/Yellow**	Vibration fork is uncovered but signal output states covered	Sensitivity is too high. Too much material build-up may be present.	Clean probe from buildup. IO-Link version: Decrease switchpoint values (SP1, SP2) If version with density 0,7 g/cm ³ is used, version with with density 0,5 g/cm ³ can be used
Green/Yellow**	Vibration fork is covered but signal output states uncovered	Sensitivity is too low. Material density may be too low.	Check if material density is within specification. IO-Link version: Increase switchpoint values (SP1, SP2) If version with density 0,5 g/cm ³ is used, version with with density 0,7 g/cm ³ can be used
Red flashing		Internal diagnostics has indicated an remediable error.	Check: <ul style="list-style-type: none"> - Output current overload / short circuit - Too low supply voltage - Too high temperature - Testmagnet too long present
Red On	Signal output = inactive	Internal diagnostics indicates a fault: Vibration fork is corroded Unit is defect.	Contact distributor.

* IO-Link version: Stated LED colours correspond to default values in Registers 96 to 100

** Green or yellow depending with use of M12 plug or Valve plug (see "Output logic and LED's").

Maintenance

Frequent check of the unit

- ! To ensure durable safety with electrical safety, following items must be checked frequently depending on the application:
- Mechanical damage or corrosion of the unit (housing side and process side) and of the field wiring cables.
 - Tight sealing of the process connection and of the connecting plug.

Cleaning

- ! If cleaning is required by the application, following must be observed:
- Cleaning agent must comply with the materials of the unit (chemical resistance).
 - The cleaning process must be done in a way that no mechanical damage of any parts can happen.

Units with EHEDG (EL class I) certification, which are used in the respective EHEDG applications, must be cleaned according to the respective regulations. The device has been developed for Cleaning in Place (CIP) or Sterilization in Place (SIP) applications and must not be dismantled for cleaning.

Max. temperature for CIP / SIP

150°C (302°F), duration continuous
 Unit de-energized.

Function test

- ! A frequent function test may be required depending on the application.
- Observe all relevant safety precautions related with a safe work depending on the application (e.g. dangerous material, electric safety, process pressure).

Function test possibilities:

Insert the vibration fork into water and monitor, if a correct change of the signal output from uncovered to covered and from covered to uncovered happens.

Alternative use of Test magnet: see chapter "Operation - Test with Test magnet"

Production date

The production date can be traced by the serial number on the typeplate. Please contact the manufacturer or your local distributor.

Spare parts

All available spare parts are stated in the selection list

Disposal

The product consists of materials which can be recycled, details of the used materials see chapter "Technical data - mechanical data". Recycling must be done by a specialised recycling company.